

Oil / Water Separator

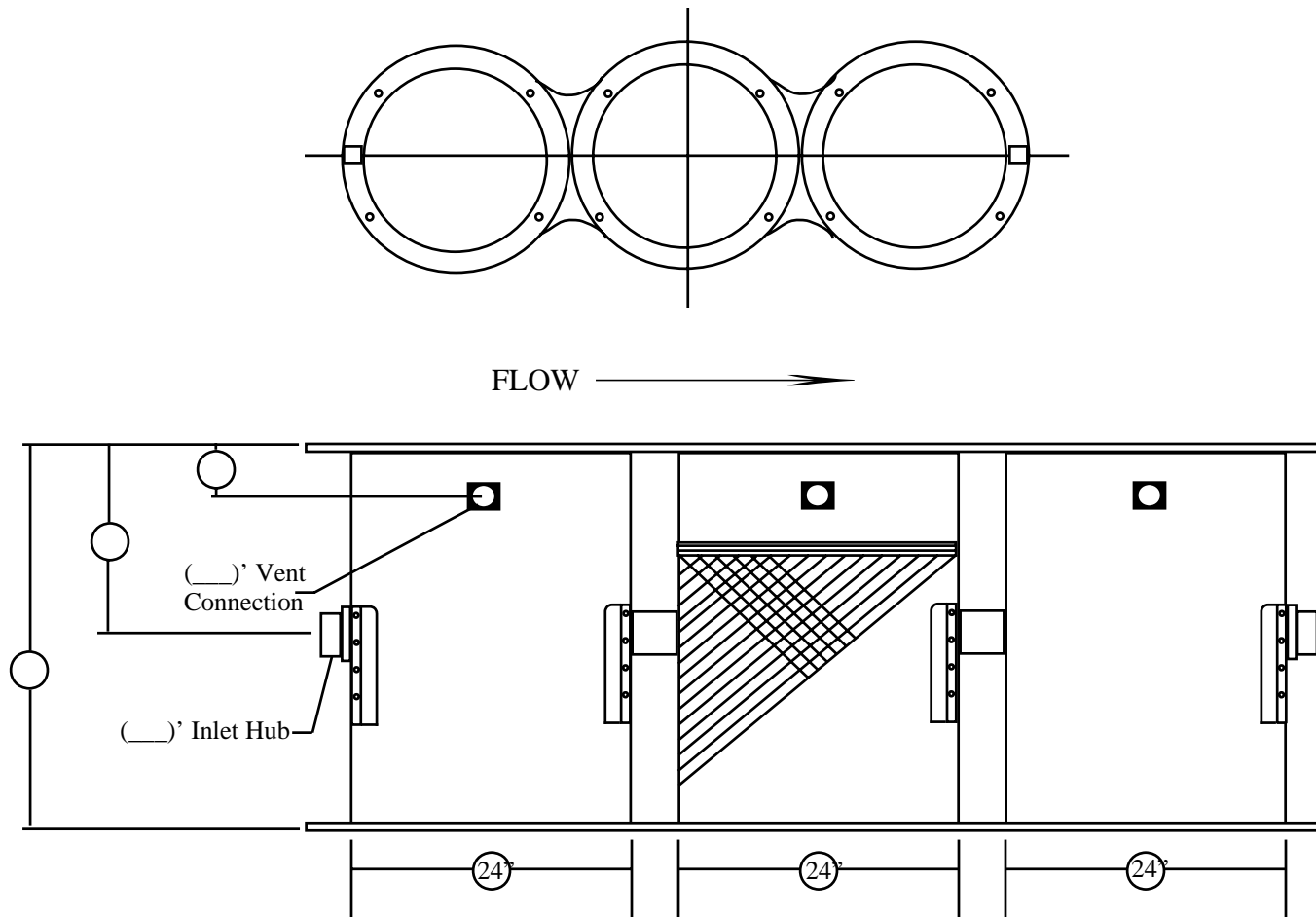

1. Supply of 24" x 60" Triple Basin Oil, Water Separator Interceptor With Coalescing Media in Second Basin.
2. WST-TB 24 x 60 To Be Built of Reinforced Fiberglass and Glassed Together For Easy Installation.
3. The Three Covers To be Constructed of 1/4" Steel Plate and Water Tight Seals. Inlet & Outlet Size and location to be Determined

FLORIDA WATER BLAST, INC
 P.O. Box 17062 Clearwater, FL 33762
 WORK # 1-800-966-0614 FAX # 1-727-572-9926

Oil / Water Separator

Part # QP-350