

Our Purifier systems are the best line of industrial jet washers in the world!

Using water based solutions, these heavy duty spray washing systems clean the dirtiest parts in just minutes. Rinse and dry stages are optional. Choose from front and top loading styles. All units have the namesake "Purifier" filtration feature to extend the life of the wash solution.

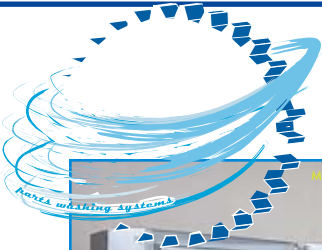

Standard Features

** model specifications are located on pages 4 through 6*



"Purifier" Filtration

The namesake feature of these models is the "Purifier" filtration system which greatly extends the life of the washing solution. After the solution hits the parts it flows through a removable stainless "chip" basket. A deflector plate then shunts the solution to the rear of the tank where most of the fine sediment is trapped in a 2" deep by 10" wide canal that spans the width of the machine. A radical floor pitch from front to back further influences the sediment toward the rear. To extract the sediment, simply remove the rear cover plates and dredge out the canal. Floating oils are continuously removed with the OSW-11 skimming system and channeled into a removable container.

PRODUCT SPECIFICATIONS

PURIFIER Systems

Standard Features cont.

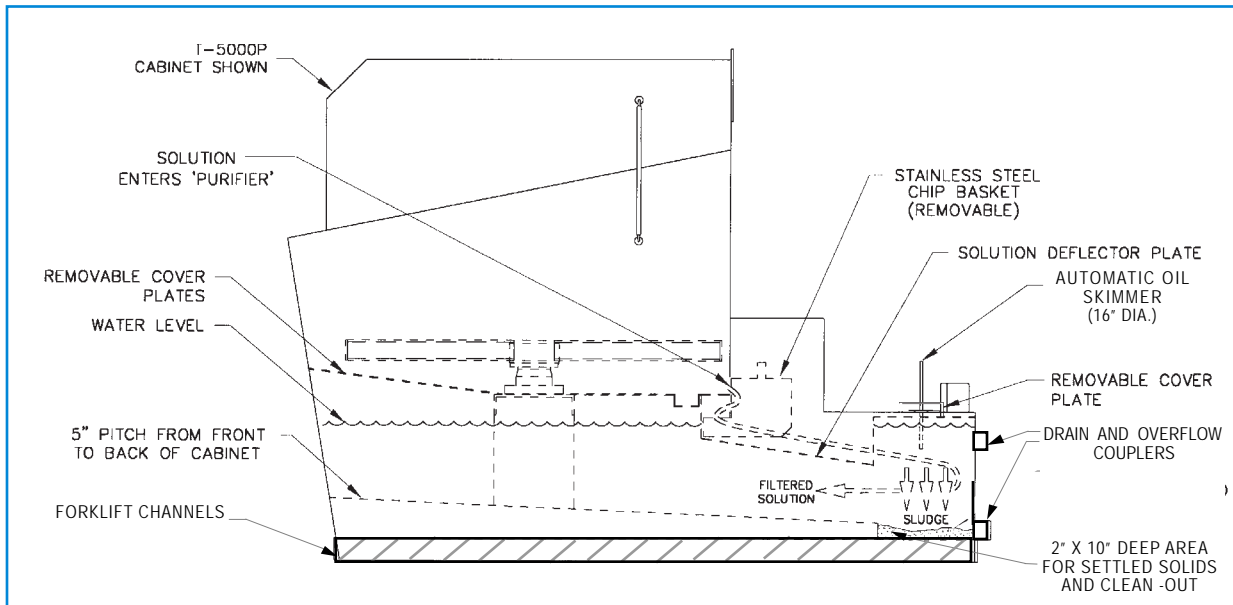

Lifetime Guarantees

- Against any welds cracking or leaking
- On the turntable and its sealed bearing assembly
- Against the door ever jamming

Front Loading Models

- 55% of the turntable is exposed, allowing a hoist chain to be positioned over the center of the turntable
- Turntable surface is within 30" of the ground
- Door is supported with a continuous hinge (full length of the door)
- Door bottom is pitched to direct all residual water back to the tank
- Labyrinth seal prevents water from escaping
- Snap-on gasket seals in steam



Top Loading Models

- The body of the cabinet slopes downward so the loading edge is within 41" of the ground and within 14" of the turntable surface
- The lid is powered up and down by an electric, linear actuator – push buttons require 2 handed operation
- Lid is supported with a continuous hinge (full length of the lid)
- Deflector plate inside the lid prevents dripping on the floor when the lid is opened
- Labyrinth seal prevents water from escaping
- Snap-on gasket seals in steam



Load Bearing/Safety

- Parts are loaded directly on the turntable (basket does not have to be rolled in and out of cabinet)
- Turntable is mounted on structural beam tied directly to the ground (the door bears none of the load and the load is never suspended or cantilevered)

Standard Features cont.



Vertical (seal-less) Pumps

- All pumps are vertical (seal-less) style units (designed to withstand abrasive particles up to ¼" in dia.)
- There are no bearings or seals beneath the solution level
- Driven with TEFC motors
- Motors have extended shafts that connect directly to the impeller (no couplings)



Turntable/ Basket/ Drive System

- Center bearing spindle is completely sealed
- External grease cup for the bearing assembly
- Turntable rim and spokes have a minimum thickness of 3/16"
- Friction drive system... foam filled tire spring loaded against turntable rim
- TEFC drive motor
- Removable parts basket (6" high side walls/1" open mesh)



Spray Manifolds

- Stainless steel "V" jet spray nozzles
- Manifolds positioned above, below, and on outside of turntable
- Front loading models have a mid-level, overhead spray manifold that pivots out of the way for tall parts
- On top loading models, overhead manifolds retract with the lid



Control System

- Nema 12 control panel and junction boxes
- 110 V controls
- Timer for wash, rinse, and dry stages
- Panel mounted thermostats with digital read-out for all heated circuits
- Control and power circuits fused
- 2 channel, 7 day/24 hour timer for water heaters and oil skimmer
- Jog button for turntable
- Door/lid safety switch
- Terminal ends of all wires are numbered

** specification tables are located on the following pages*

T-2500 Purifier



MODEL	T-2500
Inside Working Dimensions:	
<i>height</i>	18"
<i>turntable dia.</i>	25"
<i>turntable area</i>	490 sq. inches
Overall Dimensions:	
<i>width/depth/height</i>	42" x 53" x 50"
Tank Size	50 gal.
Turntable Weight Capacity	500 lbs.
Standard Power Source	230V, 3 phase
Full Load Amps	48
Pump Motor:	
<i>type</i>	vertical
<i>size</i>	3.0 HP
<i>output</i>	50 GPM / 50 PSI
Heat Source: electric	9 kW
Heat Up Time	1 hr.

** the T-2500 does not have the Purifier sediment canal*

F-3000-P Purifier



MODEL	F-3000-P
Inside Working Dimensions:	
<i>height</i>	36"
<i>turntable dia.</i>	30"
<i>turntable area</i>	710 sq. in.
Overall Dimensions:	
<i>width/depth/height</i>	45" x 62" x 69"
Tank Size	95 gal.
Turntable Weight Capacity	750 lbs.
Standard Power Source	230V, 3 phase
Full Load Amps	46
Pump Motor:	
<i>type</i>	vertical
<i>size</i>	5.0 HP
<i>output</i>	75 GPM/60 PSI
Heat Source: electric	12 kW
Heat Up Time	1.5 hr.

F-4000 Purifiers



MODEL	F-4000-P	F-4000LX-P
Inside Working Dimensions:		
<i>height</i>	40"	60"
<i>turntable dia.</i>	40"	40"
<i>turntable area</i>	1260 sq. in.	1260 sq. in.
Overall Dimensions:		
<i>width/depth/height</i>	63" x 72" x 72"	63" x 72" x 92"
Tank Size	140 gal.	140 gal.
Turntable Weight Capacity	1,500 lbs.	1,500 lbs.
Standard Power Source	230V, 3 phase	230V, 3 phase
Full Load Amps	61	67
Pump Motor:		
<i>type</i>	vertical	vertical
<i>size</i>	5.0 HP	7.5 HP
<i>output</i>	100 GPM/60 PSI	150 GPM/60 PSI
Heat Source: electric	18 kW	18 kW
Heat Up Time	1.5 hr.	1.5 hr.

F-5000 and F-6000 Purifiers



MODEL	F-5000LX-P	F-6000LX-P
Inside Working Dimensions:		
<i>height</i>	60"	60"
<i>turntable dia.</i>	50"	60"
<i>turntable area</i>	1970 sq. in.	2830 sq. in.
Overall Dimensions:		
<i>width/depth/height</i>	75" x 84" x 92"	85" x 94" x 92"
Tank Size	200 gal.	260 gal.
Turntable Weight Capacity	2,500 lbs.	2,500 lbs.
Standard Power Source	230V, 3 phase	230V, 3 phase
Full Load Amps	97	131
Pump Motor:		
<i>type</i>	vertical	vertical
<i>size</i>	10 H	15 HP
<i>output</i>	200 GPM / 60 PSI	250 GPM / 60 PSI
Heat Source: electric	27 kW	36 kW
Heat Up Time	1.5 hr.	1.25 hr.

T-5000 and T-6000 Purifiers



MODEL	T-5000-P	T-6000-P
Inside Working Dimensions:		
<i>height</i>	31"	31"
<i>turntable dia.</i>	50" *	60" *
<i>turntable area</i>	1970 sq. in.	2830 sq. in.
Overall Dimensions:		
<i>width/depth/height</i>	70" x 91" x 62"	80" x 100" x 62"
Tank Size	200 gal.	260 gal.
Turntable Weight Capacity	1,500 lbs.	2,500 lbs.
Standard Power Source	230V, 3 phase	230V, 3 phase
Full Load Amps	90	121
Pump Motor:		
<i>type</i>	vertical	vertical
<i>size</i>	7.5 HP	10 HP
<i>output</i>	150 GPM/ 60 PSI	200 GPM / 60 PSI
Heat Source: electric	27 kW	36 kW
Heat Up Time	1.5 hr.	1.25 hr.

**Reduce 2.5" for clear loading of single largest part.*

T-7000-P Purifier

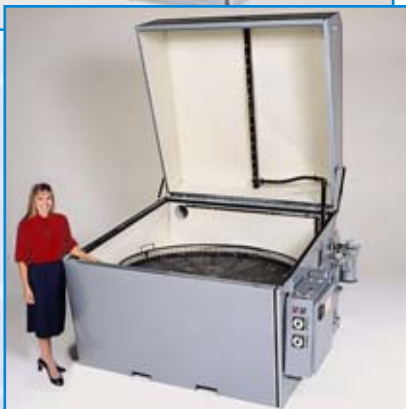

MODEL	T-7000-P
Inside Working Dimensions:	
<i>height</i>	31"
<i>turntable dia.</i>	70" *
<i>turntable area</i>	3860 sq. inches
Overall Dimensions:	
<i>width/depth/height</i>	91" x 109" x 62"
Tank Size	320 gal.
Turntable Weight Capacity	2,500 lbs.
Standard Power Source	230V, 3 phase
Full Load Amps	121
Pump Motor:	
<i>type</i>	vertical
<i>size</i>	10 HP
<i>output</i>	200 GPM / 60 PSI
Heat Source: electric	36 kW
Heat Up Time	1.75 hr.

**Reduce 2.5" for clear loading of single largest part.*

Options/Accessories



1

1) THE "ZX" CONFIGURATION...simply add the "ZX" suffix to any front loading model # (eg. F-3000-P-ZX). These ZX models have a removable upper parts basket which doubles the cleaning capacity for small parts. The pump size is increased in some cases and the spray manifolds are modified so that both baskets are sprayed from the bottom, top, and sides. To clean tall parts, remove the ZX configuration and rotate the lower overhead pipe out of the way.*

Model	Weight Capacity of Upper Basket	Larger Pump Size	Full Load Amps	Work Height for Each Basket
F-3000-P-ZX	150 lbs.	5 HP	43	15"
F-4000-P-ZX	200 lbs.	7.5 HP	65	17"
F-4000LX-P-ZX	200 lbs.	10 HP	73	27"
F-5000LX-P-ZX	250 lbs.	15 HP	95	27"
F-6000LX-P-ZX	250 lbs.	15 HP	131	27"

**Manifolds are fixed when the system has a rinse or dry cycle.*



2 and 3

2) ARC-11 RINSE SYSTEM When the wash cycle ends, there is a programmed pause to allow the wash solution to return to the "wash tank" and then the parts are sprayed with fresh water (3-5 GPM). The rinse water is automatically diverted to an outside drain connection so that the "wash tank" does not overflow and become diluted (the tank shown in the picture is for the ARC-22).



4

3) ARC-22 RINSE SYSTEM This option works the same as the ARC-11 except the rinse water is recirculated from a separate 50 gallon tank (stainless steel). This tank has its own 2.0 HP pump (mild steel), a 9 kW heater, thermostat, etc. Using 480 volt, 3 phase power, this system draws 16.5 amps. Includes LWS-F1 below.

4) DRYING SYSTEMS After the wash or wash/rinse sequence, the parts are dried by blasting them with ambient or hot air. Pictured is a 15 HP regenerative blower and a 35 kW heating system that outputs 500 CFM of air at 270 F. Consult the factory to determine specifications.

5) ILS-11 MACRO FILTER This heavy duty, cast iron filter (ASME certified at 150 psi) is installed on the pressure side of the pump to trap particles (as small as 1/32") that could otherwise clog the spray nozzles. A glycerin filled pressure gauge indicates when the filter must be cleaned. To clean the filter, simply loosen the "T" handle, swing the lid to the side, and remove the strainer basket (no tools required).

6) ILF-22 MICRO FILTER This large capacity bag filter (ASME certified to 150 psi) traps suspended particles as small as one (1) micron. Recommended for applications where minuscule redeposition cannot be tolerated. When the glycerin filled pressure gauge shows a pressure drop across the filter, simply loosen the hold down clamps, swing the lid to the side, and replace the bag insert (no tools required).



5 and 6

Options/Accessories cont.



7

7) ASX-11 STEAM EXHAUST SYSTEMS The ASX-11 evacuates the steam before you open the door or lid. A two (2) position selector switch allows the blower to start running at the beginning of a cycle or at the end. Either way, the blower automatically shuts down when the door/lid is opened. The ASX-11 consists of a ½ HP, TEFC motor and a 3/16" thick cast aluminum blower section. At 1/2" S.P., the ASX outputs 425 CFM.

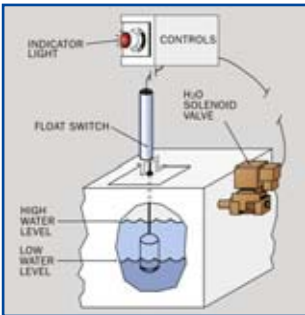

8

8) LWS - 11 / LWS-F1 WATER LEVEL CONTROLS These electro-mechanical systems prevent damage to the heating elements and pumps that can otherwise occur when the water level is low. The LWS-11 "low water shut-off" shuts down the pump and heaters when the water level reaches a critical level. An indicator light notifies the operator to correct the water level. The LWS-F1 "shut-off and auto fill" only shuts down the machine as a last resort. With this option, water is added incrementally whenever the water level falls as little as 1/4" from its' maximum level. This incremental approach keeps the water temperature relatively constant. The float sensors will never "jam" since there are no bushing or pivots points below the solution level.



9 and 10

9) RCB -11 COATED BASKETS To avoid scratching critical parts, the parts basket is coated with a highly elastic, polyvinyl material.

10) SPB-11 SMALL PARTS BASKET To contain small parts, choose one of the SPB-11 baskets which have hinged lids. The small basket is 12" long x 6" wide x 6" high. The larger one is 15" long x 9" wide x 6" high.



11

11) SST-11 SIDE TRAY With the SST-11, you can hand detail parts with the same jet washer solution and without having to buy or rent an additional piece of equipment. A stainless steel wash basin (24" long x 18" wide x 4" deep) is attached to the side of your jet washer. A stainless steel pump brings the hot solution to the hand brush and the solution then drains back to the jet washer.



12

12) JET WASHING DETERGENTS These detergents are specially formulated for a jet washer, maximizing the cleaning performance and the protection of your machine. These detergents, backed by a chemistry department and factory test center, allow Better Engineering to take a full service approach to your cleaning problems.